

FREEZER(LEFT)

SF-104 TEMPERATURE CONTROLLER

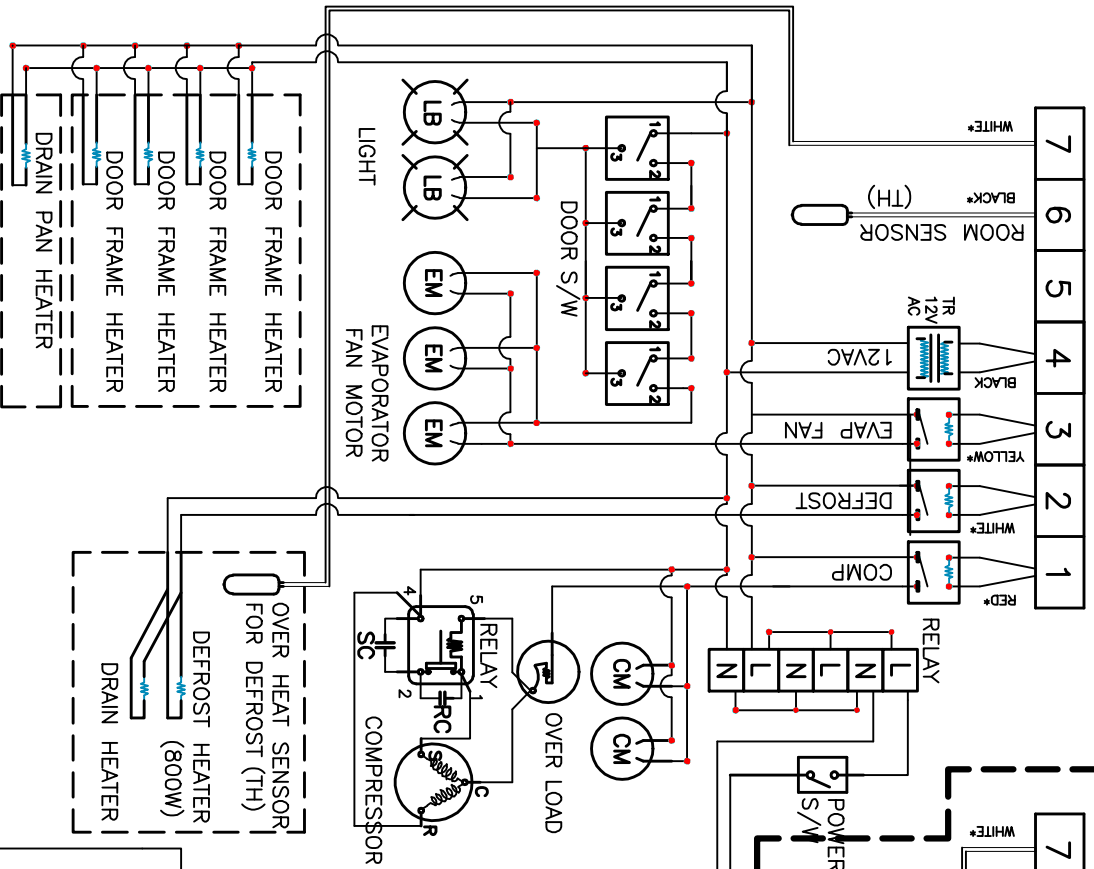

FREEZER(RIGHT)

SF-104 TEMPERATURE CONTROLLER

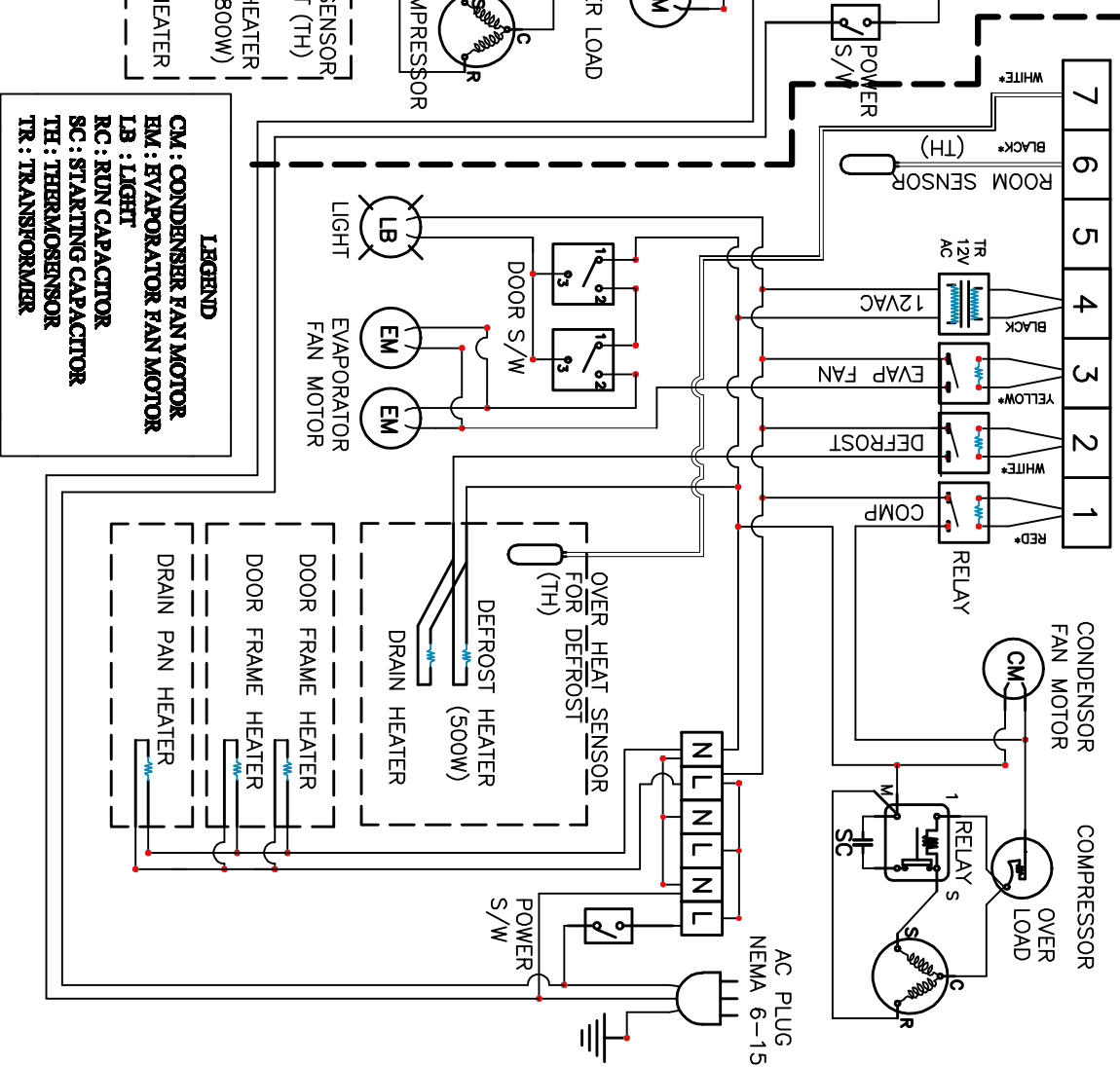

- LEGEND**
- CM : CONDENSER FAN MOTOR
 - EM : EVAPORATOR FAN MOTOR
 - LB : LIGHT
 - RC : RUN CAPACITOR
 - SC : STARTING CAPACITOR
 - TH : THERMOSENSOR
 - TR : TRANSFORMER

CONTROL WIRING DIAGRAM (JHD-61F)

AC 220V