

COOLER

SF-102 TEMPERATURE CONTROLLER

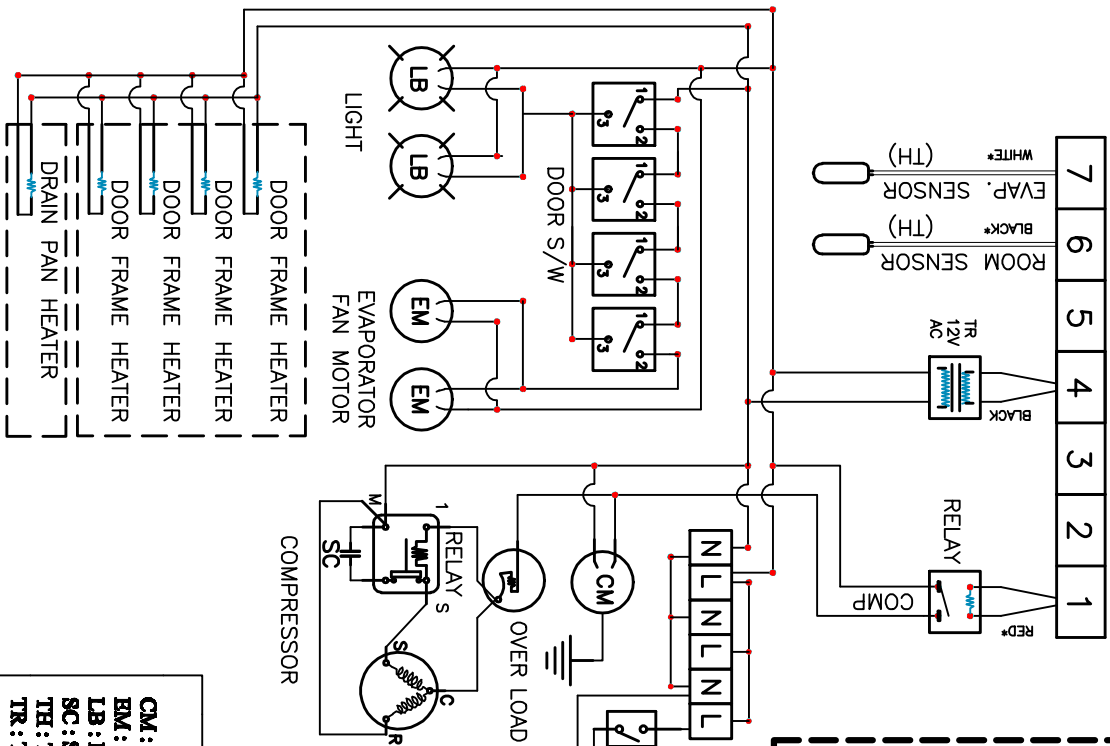

REFRIG

SF-104 TEMPERATURE CONTROLLER

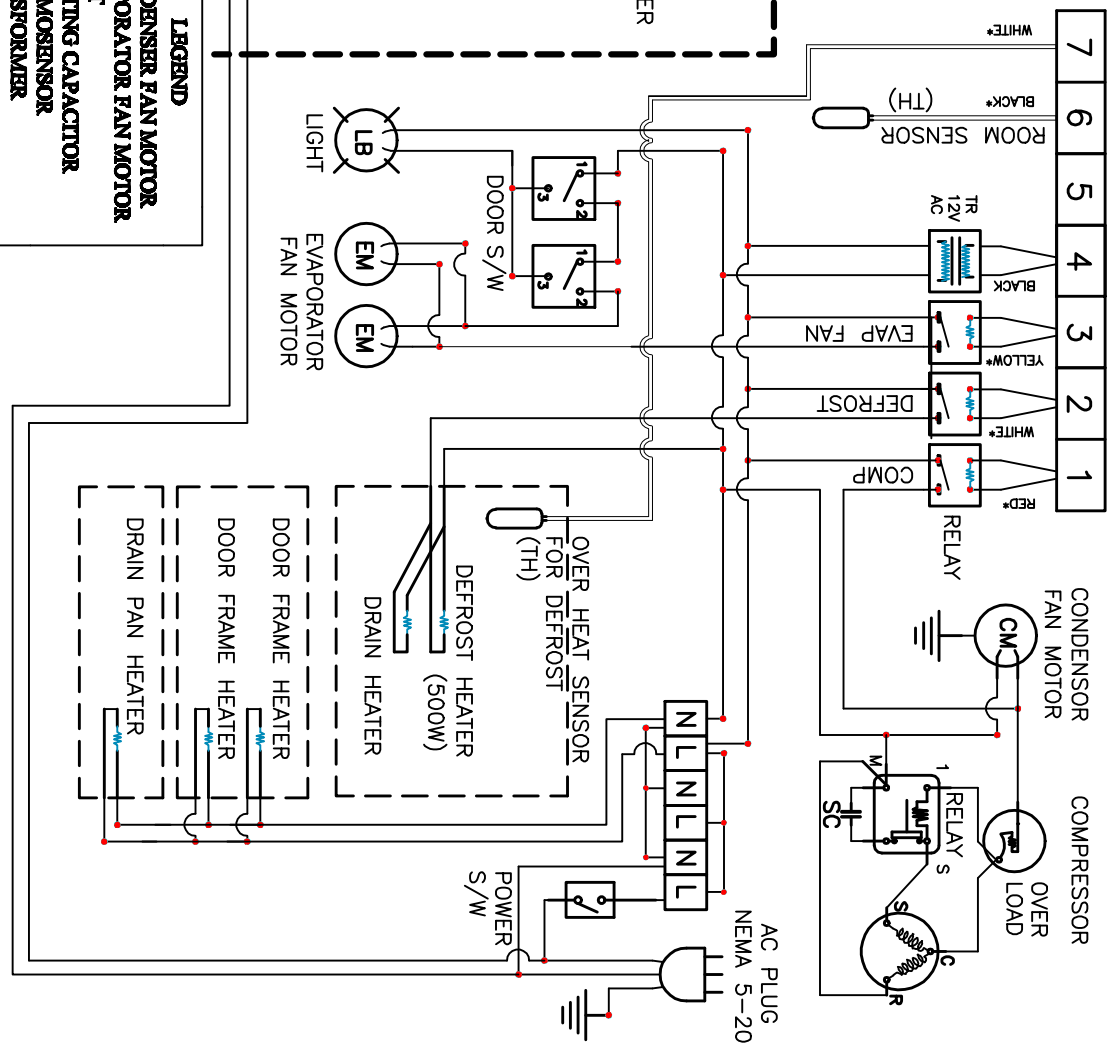

LEGEND
 CM : CONDENSER FAN MOTOR
 EM : EVAPORATOR FAN MOTOR
 LB : LIGHT
 SC : STARTING CAPACITOR
 TH : THERMOSENSOR
 TR : TRANSFORMER

CONTROL WIRING DIAGRAM (JHD-61DT) AC 115V