



Reaching New Heights

Date Modified 11/13/08

Six Half Door Refrigerator



JHD-61R

61 cu.ft., 3 section



Patent # **D445, 159S**
D445, 160S
D445, 161S

- Stainless steel interior & exterior standard!***
- Recessed door handles!***
- Exterior digital temperature controls!***
- Convenient low box height design!***
- Energy saving half door design!***

STANDARD FEATURES:

- Recessed Door Handles
- Self-Contained Top Mounted Refrigeration System
- 2 Vinyl-Coated Wire Shelves per Door
- 5" Casters Included
- Specifically Designed 76.2" High for Easy Mobility and Installation
- Reinforced Door Hinges
- CFC-free R-134a Refrigerant
- Evaporative Electric Condensate Pan
- Fully Coved Interior Corners
- Automatic Door Closure with 90° Hold Open Feature
- Door Locks
- 2.5" Thick Foamed-in-place Polyurethane Insulation
- Exterior Digital Temperature Control
- Snap-In Magnetic Door Gaskets
- Assembled in USA

MATERIALS:

INTERIOR: Stainless steel interior walls, floor, and ceiling.
Vinyl-coated wire shelves.
EXTERIOR: Stainless steel sides and doors



NSF/ANSI Standard 7



ACCREDITED

ISO 17025:2005 Certified

DIMENSIONAL DATA:

Model No.	L	D	H	Doors	Cu.Ft.	Shelves	H/P	Volt	Amp.	NEMA	Ship Wt.
JHD-61R	74.8"	31.8"	76.2"	6	61	12	1/3,1/5	115/60/1	10.9	5-20P	715



Solid Door Refrigerator

JHD-61R

Description: Six solid half door refrigerator, 61 cu. ft.

Features & Benefits

Stainless steel interior and exterior for greater durability, construction and appearance.

Recessed door handles with plastic door handle gaskets for ease of use.

Self-contained top mounted refrigeration system and high humidity coated fin coil evaporator.

- Holds 30° F to 45° F as refrigerator

Automatic interior light in both refrigerator sections. Cabinet is partitioned to keep one section at a separate temperature than the other section.

*Exterior LED temperature display with digital controls. **Temperature setting is easy, fast and accurate.***

Micro-controller with adjustable temperature variance, setpoint limits, and parameter locking functions.

12 adjustable vinyl-coated steel wire shelves.

*5" casters standard. **Easy mobility and installation.***

Convenient and energy-efficient half-door design.

*Electric condensate evaporator - **no floor drain required!***

Reinforced door hinges with 90 degree hold open feature.

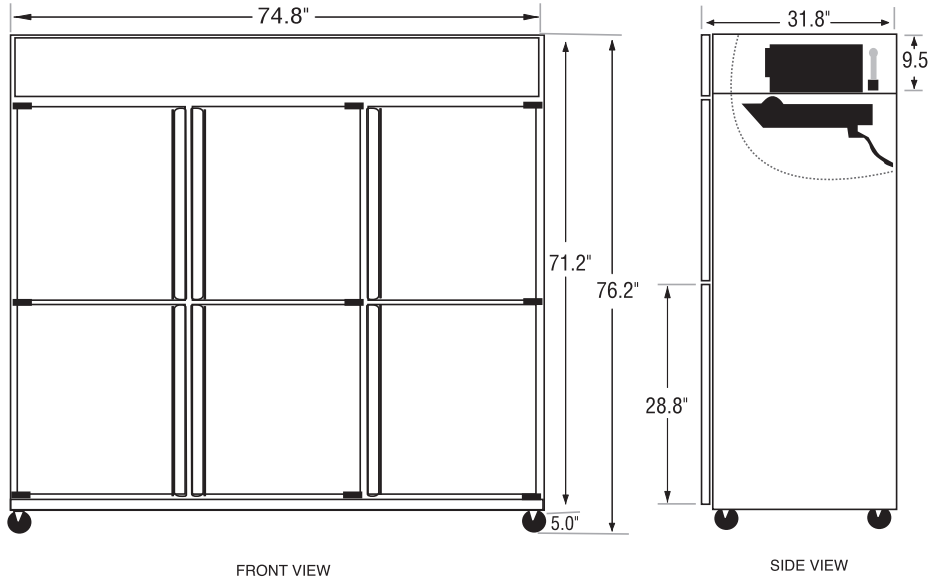
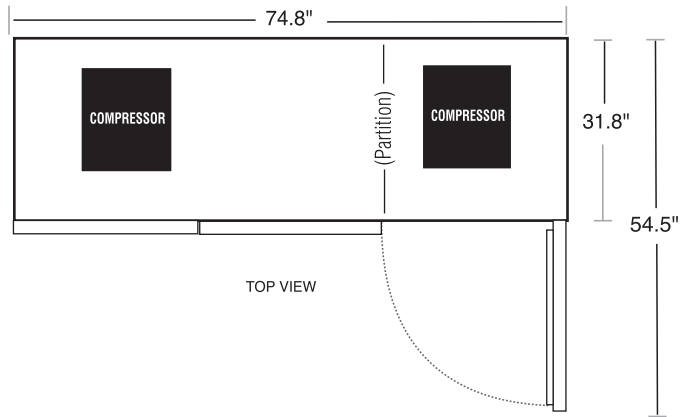

FACTORY OPTIONS		
Suffix 1	Suffix 2	Description
-6G		Glass doors, light switches
-4G		4 glass doors, light switches
	-L	Left 4 glass doors
	-R	Right 4 glass doors
-3G		3 glass doors, light switches
More glass door configurations available, see price list		



NEMA 5-20P plug
5-20R receptacle required

General Information

Cubic Ft.: 61

Half Doors: 6

Exterior: Stainless

Interior: Stainless

Shelf Size: 24.75"x20.5" (x4) 24.5" x 22" (x8)

Unit Weight: 690 lbs.

Ship Weight: 715 lbs.

Technical Data

Refrigerant: R-134A

Start Amps: 16.3

Run Amps: 10.9

Horsepower: 1/3,1/5

Volts: 115

#Compressors: 2

Cord Length: 82 in.