



Reaching New Heights

Date Modified 3/4/09

Two Half Door Refrigerator



JHD-21R
21 cu.ft., 1 section

Patent # D445, 159S
D445, 160S
D445, 161S

Stainless steel interior & exterior standard!
Recessed door handles!
Exterior digital temperature controls!
Convenient low box height design!
Energy saving half door design!

STANDARD FEATURES:

- Recessed Door Handles
- Self-Contained Top Mounted Refrigeration System
- 2 Vinyl-Coated Wire Shelves per Door
- 5" Casters Included
- Specifically Designed 76.2" High for Easy Mobility and Installation
- Reinforced Door Hinges
- CFC-free R-134a Refrigerant
- Evaporative Electric Condensate Pan
- Fully Covered Interior Corners
- Automatic Door Closure with 90° Hold Open Feature
- Door Locks
- 2.5" Thick Foamed-in-place Polyurethane Insulation
- Exterior Digital Temperature Control
- Snap-In Magnetic Door Gaskets
- Assembled in USA

MATERIALS:

INTERIOR: Stainless steel interior walls, floor, and ceiling.
Vinyl-coated wire shelves.

EXTERIOR: Stainless steel sides and doors



NSF/ANSI Standard 7



DIMENSIONAL DATA:

Model No.	L	D	H	Doors	Cu.Ft.	Shelves	H/P	Volt	Amp.	NEMA	Ship Wt
JHD-21R	29.1"	31.8"	76.2"	2	21	4	1/5	115/60/1	4.7	5-15P	325



Solid Door Refrigerator

JHD-21R

Description: Two solid half door refrigerator, 21 cu. ft.

Features & Benefits

Stainless steel interior and exterior for greater durability, construction and appearance.

Recessed door handles with plastic door handle gaskets for ease of use.

Self-contained top mounted refrigeration system and high humidity coated fin coil evaporator.

- Holds 30° F to 45° F as refrigerator

Automatic interior light.

Exterior LED temperature display with digital controls. Temperature setting is easy, fast and accurate.

Micro-controller with adjustable temperature variance, setpoint limits, and parameter locking functions.

4 adjustable vinyl-coated steel wire shelves.

5" casters standard. Easy mobility and installation.

Convenient and energy-efficient half-door design.

Heavy-duty overall construction for high-volume, constant duty operation.

Electric condensate evaporator - no floor drain required!

Reinforced door hinges with 90 degree hold open feature.

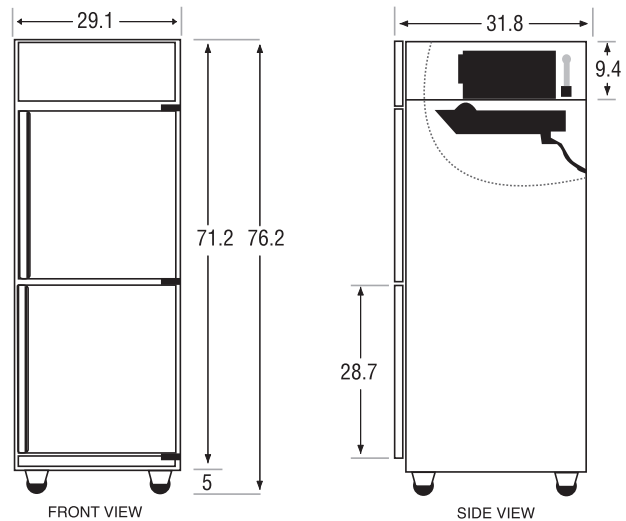
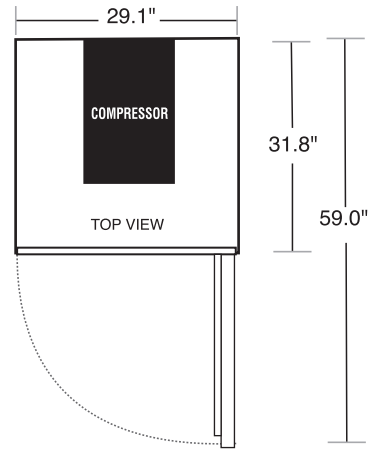

FACTORY OPTIONS

Suffix 1	Suffix 2	Description
-LH		Left Hinge
-2G		Glass doors, light switch
-1G		Top glass door, light switch
	-B	Bottom glass door



NEMA 5-15P plug
5-15R receptacle required

General Information

Cubic Ft.: 21
Shelf Size: 24.75"x24"

Half Doors: 2
Unit Weight: 305 lbs.

Exterior: Stainless
Ship Weight: 325 lbs.

Interior: Stainless

Technical Data

Refrigerant: R-134A
Volts: 115

Start Amps: 6.1
#Compressors: 1

Run Amps: 4.7
Cord Length: 82 in.

Horsepower: 1/5