



*Reaching New Heights*

Date Modified 11/13/08

**Two Half Door Refrigerator/Freezer**



**JHD-20DT**  
20 cu.ft., 1 section



Patent # **D445, 159S**  
**D445, 160S**  
**D445, 161S**

***Stainless steel interior & exterior standard!***  
***Recessed door handles!***  
***Exterior digital temperature controls!***  
***Convenient low box height design!***

**STANDARD FEATURES:**

- Recessed Door Handles
- Self-Contained Top Mounted Refrigeration System
- 2 Vinyl-Coated Wire Shelves per Door
- 5" Casters Included
- Specifically Designed 76.2" High for Easy Mobility and Installation
- Reinforced Door Hinges
- CFC-free R-134a & R-404a Refrigerant
- Evaporative Electric Condensate Pan
- Fully Covered Interior Corners
- Automatic Door Closure with 90° Hold Open Feature
- Door Locks
- 2.5" Thick Foamed-in-place Polyurethane Insulation
- Exterior Digital Temperature Control
- Snap-In Magnetic Door Gaskets
- Assembled in USA

**MATERIALS:**

INTERIOR: Stainless steel interior walls, floor, and ceiling.  
Vinyl-coated wire shelves.  
EXTERIOR: Stainless steel sides and doors



NSF/ANSI Standard 7



ACCREDITED

ISO 17025:2005 Certified

**DIMENSIONAL DATA:**

Model No.	L	D	H	Doors	Cu.Ft.	Shelves	H/P	Volt	Amp.	NEMA	Ship Wt.
JHD-20DT	29.1"	31.8"	76.2"	2	20	4	1/5,1/4	115/60/1	10.7	5-15P	350



# Solid Door Freezer / Refrigerator

## JHD-20DT

Description: Two solid half door REF (1 dr) FRE(1 dr), 20 cu. ft.

### Features & Benefits

**Stainless steel interior and exterior for greater durability, construction and appearance.**

**Recessed door handles with plastic door handle gaskets for ease of use.**

**Self-contained top mounted refrigeration system and high humidity coated fin coil evaporator.**

- Holds -10° F to 10° F as freezer
- Holds 30° F to 45° F as refrigerator

**Automatic interior lights.**

**Exterior LED temperature display with digital controls. Temperature setting is easy, fast and accurate.**

**Micro-controller with adjustable temperature variance, automatic defrost intervals, setpoint limits, and parameter locking functions.**

**4 adjustable vinyl-coated steel wire shelves.**

**5" casters standard. Easy mobility and installation.**

**Convenient and energy-efficient half-door design.**

**Heavy-duty overall construction for high-volume, constant duty operation.**

**Electric condensate evaporator - no floor drain required!**

**Reinforced door hinges with 90 degree hold open feature.**

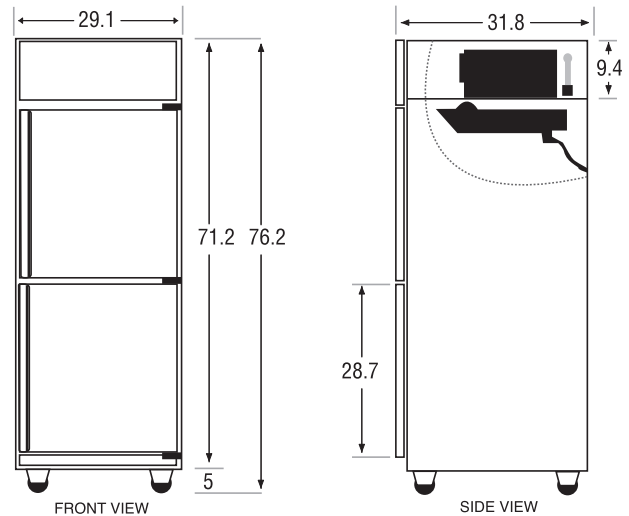
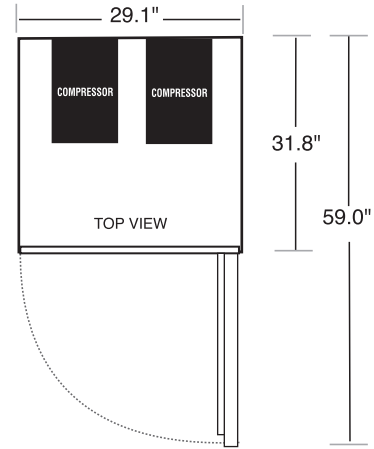

### FACTORY OPTIONS

Suffix	Description
-LH	Left Hinge
-FB	Freezer Bottom reconfiguration
-1G	Top glass door(REF only), light switch



NEMA 5-15P plug  
5-15R receptacle required

### General Information

**Cubic Ft.:** 20

**Shelf Size:** 24.75"x20.5"

**Half Doors:** 2

**Unit Weight:** 325 lbs.

**Exterior:** Stainless

**Ship Weight:** 350 lbs.

**Interior:** Stainless

### Technical Data

**Refrigerant:** R-404A & R-134A

**Volts:** 115

**Start Amps:** 13.2

**#Compressors:** 2

**Run Amps:** 10.7

**Cord Length:** 82 in.

**Horsepower:** 1/5, 1/4