



Reaching New Heights

Date Modified 11/13/08

Three Full Door Refrigerator



JFD-72R
72 cu.ft., 3 section

Stainless steel interior & exterior standard!
Fully-recessed door handles!
Slide shelving system!
Exterior digital temperature controls!

STANDARD FEATURES:

- Fully Recessed Door Handles
- Self-Contained Bottom Mounted Refrigeration System
- 9 Vinyl-Coated Wire Shelves
- 5" Casters Installed
- Door Locks
- Reinforced Door Hinges
- CFC-free R-134a Refrigerant
- Evaporative Hot Gas Condensate Pan
- Fully Coved Interior Corners
- Automatic Door Closure with 90° Hold Open Feature
- Slide Shelving System
- 2.5" Thick Foamed-in-place Polyurethane Insulation
- Exterior Digital Temperature Control
- Snap-In Magnetic Door Gaskets
- Assembled in USA

MATERIALS:

INTERIOR: Stainless steel interior walls, floor, and ceiling.
Vinyl-coated wire shelves.
EXTERIOR: Stainless steel sides and doors



NSF/ANSI Standard 7



ISO 17025:2005 Certified

DIMENSIONAL DATA:

Model No.	L	D	H	Cu.Ft.	Shelves	H/P	Volt	Amp.	NEMA	Ship Wt.
JFD-72R	81.0"	32.3"	81.8"	72	9	1/2	115/60/1	9.9	5-20P	690



Solid Door Refrigerator

JFD-72R

Description: Three solid full door refrigerator, 72 cu. ft

Features & Benefits

Stainless steel interior and exterior for greater durability, construction and appearance.

Self-contained bottom mounted refrigeration system and high humidity coated **fin coil** evaporator.

- Holds 30° F to 45° F as refrigerator

Exterior LED temperature display with digital controls. **Temperature setting is easy, fast and accurate.**

Micro-controller with adjustable temperature variance, automatic defrost intervals, setpoint limits, and parameter locking functions.

2.5" thick, foamed-in-place polyurethane high density insulation.

9 adjustable vinyl-coated steel wire shelves. Built-in tray slides to accommodate shelves (standard) or 18"x26" sheet pans (optional).

5" casters standard. **Easy mobility and installation.**

Heavy-duty overall construction for high-volume, constant duty operation.

Self-closing door with 90° hold open feature.

Door locks standard.

Door handle gaskets for ease of use.

Hot gas condensate - **no floor drain required!**

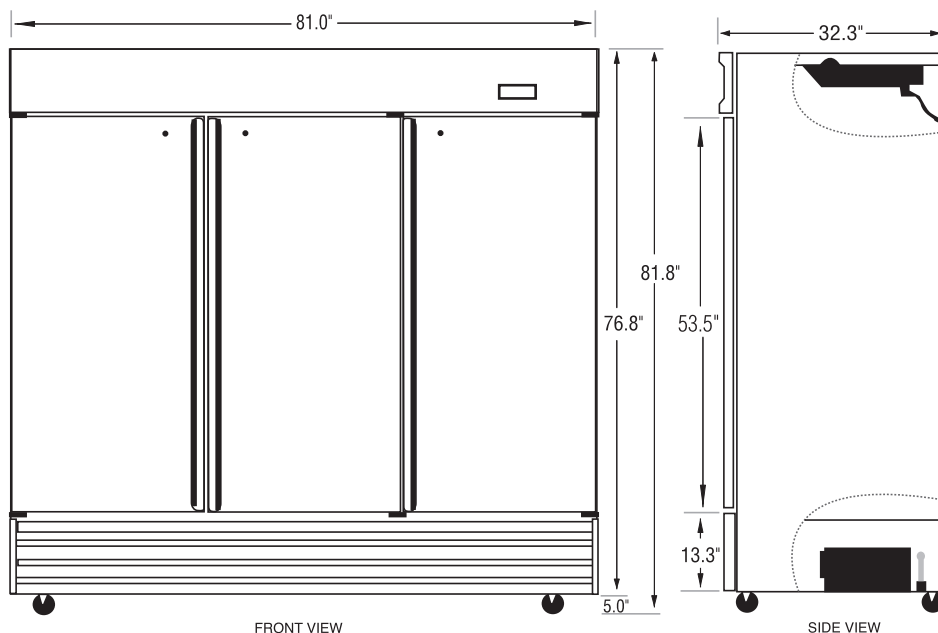
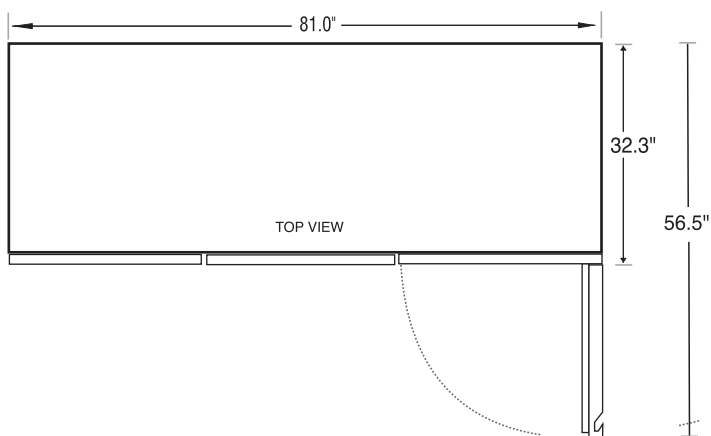

FACTORY OPTIONS

Suffix1	Suffix2	Description
-3G		3 glass doors, light switches
-2G		2 glass doors, light switches
	-L	Left 2 glass doors
	-R	Right 2 glass doors
-1G		1 glass door, light switch
	-L	Left 1 glass door
	-R	Right 1 glass door
	-M	Middle 1 glass door



NEMA 5-20P plug

5-20R receptacle required

General Information

Cubic Ft.: 72

Doors: 3

Exterior: Stainless

Interior: Stainless

Shelf Size: 25.0" x 20.75"

Unit Weight: 650 lbs.

Ship Weight: 690 lbs.

Technical Data

Refrigerant: R-134a

Start Amps: 12.5

Run Amps: 9.9

Horsepower: 1/2

Volts: 115

#Compressors: 1

Cord Length: 82 in.

SPECIFICATIONS SUBJECT TO CHANGE WITHOUT NOTICE