



Reaching New Heights

Date Modified 11/6/08

One Full Door Refrigerator



JFD-23R
23 cu.ft., 1 section

Stainless steel interior & exterior standard!
Fully-recessed door handles!
Slide shelving system!
Exterior digital temperature controls!

STANDARD FEATURES:

- Fully Recessed Door Handles
- Self-Contained Bottom Mounted Refrigeration System
- 3 Vinyl-Coated Wire Shelves
- 5" Casters Included
- Door Lock
- Reinforced Door Hinges
- CFC-free R-134a Refrigerant
- Evaporative Hot Gas Condensate Pan
- Fully Covered Interior Corners
- Automatic Door Closure with 90° Hold Open Feature
- Slide Shelving System
- 2.5" Thick Foamed-in-place Polyurethane Insulation
- Exterior Digital Temperature Control
- Snap-In Magnetic Door Gaskets
- Assembled in USA

MATERIALS:

INTERIOR: Stainless steel interior walls, floor, and ceiling.
Vinyl-coated wire shelves.

EXTERIOR: Stainless steel sides and door



DIMENSIONAL DATA:

Model No.	L	D	H	Cu.Ft.	Shelves	H/P	Volt	Amp.	NEMA	Ship Wt.
JFD-23R	29.1"	32.3"	81.8"	23	3	1/3	115/60/1	8.1	5-15P	300



Solid Door Refrigerator

JFD-23R

Description: One solid full door refrigerator, 23 cu. ft

Features & Benefits

Stainless steel interior and exterior for greater durability, construction and appearance.

Self-contained bottom mounted refrigeration system and high humidity coated **fin coil** evaporator.

- Holds 30° F to 45° F as refrigerator

Exterior LED temperature display with digital controls. **Temperature setting is easy, fast and accurate.**

Micro-controller with adjustable temperature variance, automatic defrost intervals, setpoint limits, and parameter locking functions.

2.5" thick, foamed-in-place polyurethane high density insulation.

3 adjustable vinyl-coated steel wire shelves. Built-in tray slides to accommodate shelves (standard) or 18"x26" sheet pans (optional).

5" casters standard. **Easy mobility and installation.**

Heavy-duty overall construction for high-volume, constant duty operation.

Self-closing door with 90° hold open feature.

Door lock standard.

Door handle gaskets for ease of use.

Hot gas condensate - **no floor drain required!**

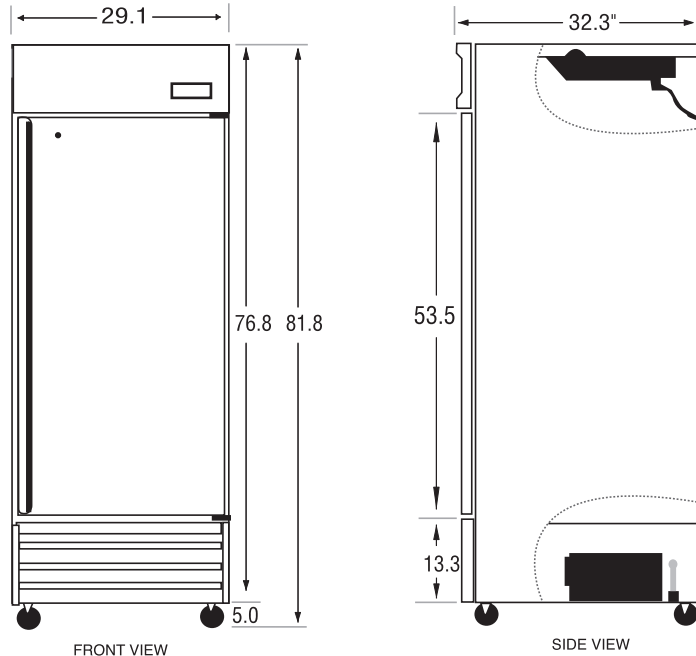
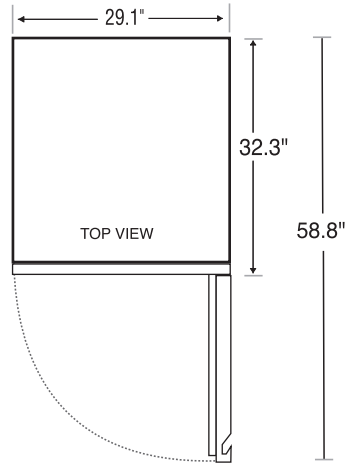

FACTORY OPTIONS

Suffix	Description
-1G	Glass Door, light switch



NEMA 5-15P plug
5-15R receptacle required

General Information

Cubic Ft.: 23

Doors: 1

Exterior: Stainless

Interior: Stainless

Shelf Size: 25.0" x 20.75"

Unit Weight: 270 lbs.

Ship Weight: 300 lbs.

Technical Data

Refrigerant: R-134a

Start Amps: 9.4

Run Amps: 8.1

Horsepower: 1/3

Volts: 115

#Compressors: 1

Cord Length: 82 in.

SPECIFICATIONS SUBJECT TO CHANGE WITHOUT NOTICE