



*Reaching New Heights*

Date Modified 3/4/09

**One Full Door Freezer**



**JFD-23F**  
23 cu.ft., 1 section

***Stainless steel interior & exterior standard!***  
***Fully-recessed door handles!***  
***Slide shelving system!***  
***Exterior digital temperature controls!***

**STANDARD FEATURES:**

- Fully Recessed Door Handles
- Self-Contained Bottom Mounted Refrigeration System
- 3 Vinyl-Coated Wire Shelves
- 5" Casters Included
- Door Lock
- Reinforced Door Hinges
- CFC-free R-404a Refrigerant
- Evaporative Hot Gas Condensate Pan
- Fully Coved Interior Corners
- Automatic Door Closure with 90° Hold Open Feature
- Slide Shelving System
- 2.5" Thick Foamed-in-place Polyurethane Insulation
- Exterior Digital Temperature Control
- Snap-In Magnetic Door Gaskets
- Assembled in USA

**MATERIALS:**

INTERIOR: Stainless steel interior walls, floor, and ceiling.  
Vinyl-coated wire shelves.

EXTERIOR: Stainless steel sides and door



NSF/ANSI Standard 7



C LISTED US

**DIMENSIONAL DATA:**

Model No.	L	D	H	Cu.Ft.	Shelves	H/P	Volt	Amp.	NEMA	Ship Wt.
JFD-23F	29.1"	32.3"	81.8"	23	3	1/2	115/60/1	8.5	5-15P	320



## Solid Door Freezer

# JFD-23F

Description: One solid full door freezer, 23 cu. ft

### Features & Benefits

**Stainless steel interior and exterior for greater durability, construction and appearance.**

Self-contained bottom mounted refrigeration system and high humidity coated **fin coil** evaporator.

- Holds -10° F to 10° F as freezer

Exterior LED temperature display with digital controls. **Temperature setting is easy, fast and accurate.**

Micro-controller with adjustable temperature variance, automatic defrost intervals, setpoint limits, and parameter locking functions.

2.5" thick, foamed-in-place polyurethane high density insulation.

3 adjustable vinyl-coated steel wire shelves. Built-in tray slides to accommodate shelves (standard) or 18"x26" sheet pans (optional).

5" casters standard. **Easy mobility and installation.**

Heavy-duty overall construction for high-volume, constant duty operation.

Self-closing door with 90° hold open feature.

**Door lock** standard.

Door handle gaskets for ease of use.

Hot gas condensate - **no floor drain required!**

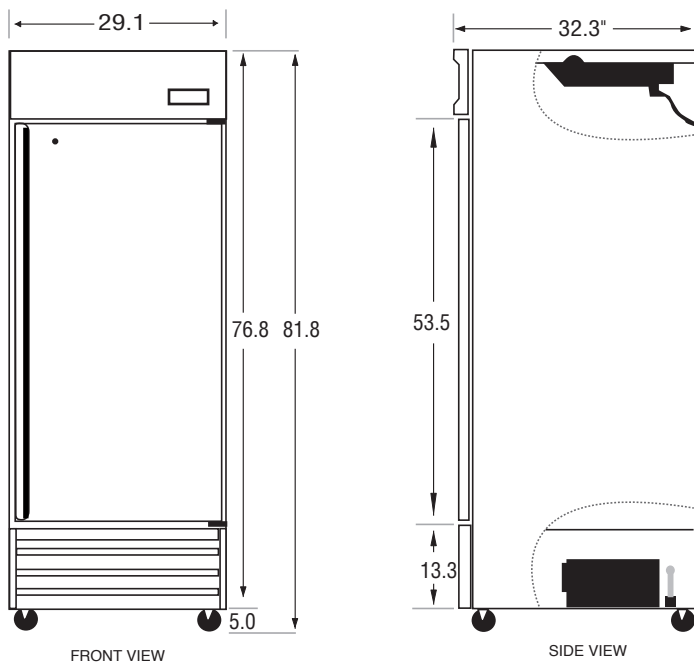
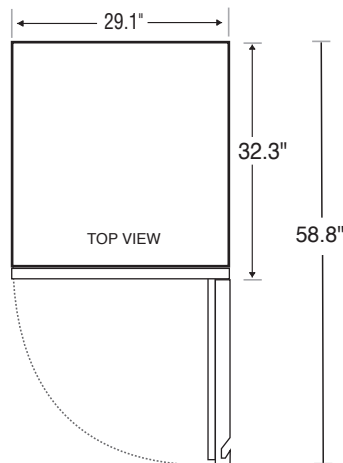

NEMA 5-15P plug  
5-15R receptacle required

### General Information

**Cubic Ft.:** 23

**Doors:** 1

**Exterior:** Stainless

**Interior:** Stainless

**Shelf Size:** 25.0" x 20.75"

**Unit Weight:** 290 lbs.

**Ship Weight:** 320 lbs.

### Technical Data

**Refrigerant:** R-404a

**Start Amps:** 10.6

**Run Amps:** 8.5

**Horsepower:** 1/2

**Volts:** 115

**#Compressors:** 1

**Cord Length:** 82 in.

SPECIFICATIONS SUBJECT TO CHANGE WITHOUT NOTICE