



Reaching New Heights

Date modified 10/11/09

Horizontal Bottle Cooler



JBC-65
65" wide, 22 cases (12 oz. bottles)

- Stainless steel interior bottom standard!
- Door locks standard!
- Reinforced Countertop!

STANDARD FEATURES:

- Capillary tube
- CFC-free R-134a Refrigerant
- 3 Vinyl Coated Bin Dividers
- Lid (door) locks
- Adjustable Bullet Feet
- Foamed-in-place Polyurethane Insulation
- Forced Air Refrigeration
- Removable Bottle Opener & Cap Catcher
- Side-Mounted Compressor
- Hot Gas Condensate Pan
- Thermostatic Control
- Assembled in the USA

MATERIALS:

- INTERIOR:** Stainless steel interior bottom for durability and appearance.
Galvanized powder coated steel walls.
- EXTERIOR:** Stainless steel countertop and lids.
Galvanized laminated matte black finish



This equipment is intended for the storage and display of non-potentially-hazardous bottled or canned products only

NSF/ANSI Standard 7

DIMENSIONAL DATA:

Model No.	L	D	H	Lids	Dividers	H/P	Volt	Amp.	NEMA	Shipping Wt.
JBC-65	65.25	28.0	34.75	2	3	1/3	115/60/1	8.2	5-15P	355



Horizontal Bottle Cooler

JBC-65

Description: Horizontal Bottle Cooler, 65 in. wide

Features & Benefits

Stainless steel interior bottom for greater durability, construction and appearance.

Self-contained **side-mounted refrigeration** with high humidity coated fin coil evaporator. Breathes from the front, back, and side.

- Holds 33° F to 41° F

2.5" thick, foamed-in-place polyurethane high density insulation.

Stainless steel lids and reinforced countertop.

Adjustable bullet feet for extra height requirements (if necessary).

Laminated matte black exterior for extra durability against the elements.

Lid (door) locks standard.

Includes 3 vinyl coated wire bin dividers, adjustable in 2 inch increments.

Built-on removable bottle opener and cap catcher standard.

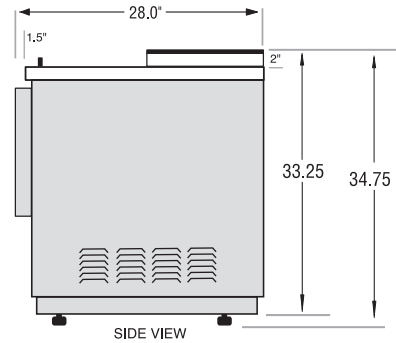

SIDE VIEW

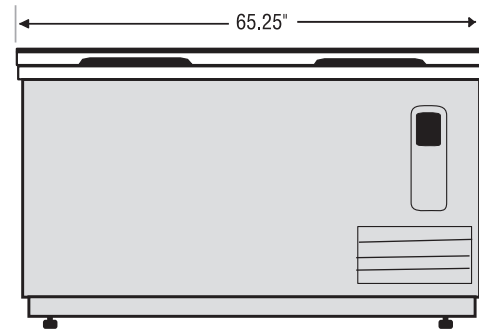

FRONT VIEW



TOP VIEW

OPTIONS

- Extra Bin Dividers Qty. _____
- Other Specify _____

General Information

Exterior: Laminated

Interior: Powder Coated Steel, Stainless Steel bottom

#Dividers: 3

Unit Weight: 315 lbs.

Ship Weight: 355 lbs.

Technical Data

Refrigerant: R-134a

Start Amps: 10.6

Run Amps: 8.2

Horsepower: 1/3

Volts: 115

#Compressors: 1

Cord Length: 104 in.

SPECIFICATIONS SUBJECT TO CHANGE WITHOUT NOTICE