

Date Modified 10/11/09

Horizontal Bottle Cooler



JBC-50

49.5" wide, 18 cases (12 oz. bottles)



Standard Features

- Capillary Tube
- Adjustable Bullet Feet (if necessary)
- Side-Mounted Compressor
- CFC-free R-134a Refrigerant
- Foamed-in-place Polyurethane Insulation
- Hot Gas Condensate Pan
- 3 Epoxy Coated Bin Dividers
- Forced Air Refrigeration
- Thermostatic Control
- Lid (door) Locks
- Removable Bottle Opener & Cap Catcher
- Reinforced Countertop
- Assembled in the USA

Materials

- INTERIOR: Stainless steel interior bottom for durability and appearance
Galvanized powder coated steel walls
- EXTERIOR: Stainless steel countertop and lids
Galvanized laminated matte black finish



This equipment is intended for the storage and display of non-potentially-hazardous bottled or canned products only

NSF/ANSI Standard 7

GENERAL INFORMATION

Dimensions: 49.5" (W) x 28" (D) x 34.75" (H)	Lids: 2
Dividers: 3	Exterior: Laminated
Unit Weight: lbs. 220	Interior: Powder coated steel, stainless steel bottom
Ship Weight: 260 lbs.	

TECHNICAL DATA

Refrigerant: R-134A	Start Amps: 9.6	Run Amps: 8.2
Horsepower: 1/5	Volts: 115	#Compressors: 1





JBC-50

Horizontal Bottle Cooler

ELECTRICAL PLUG



NEMA 5-15P plug
5-15R receptacle
required

DIMENSIONAL INFORMATION



TOP VIEW

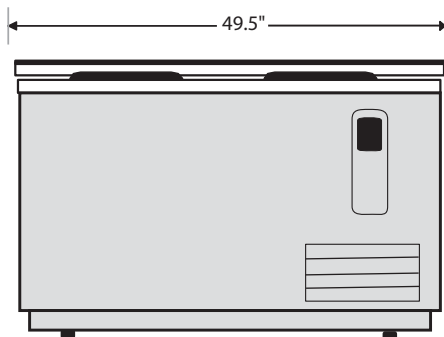

FRONT VIEW

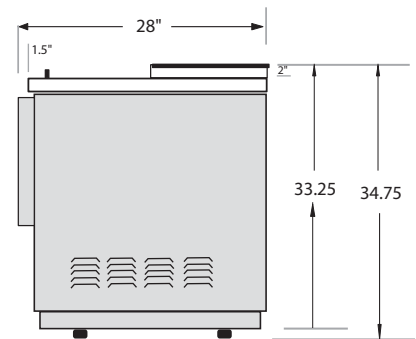

SIDE VIEW

FEATURES & BENEFITS

- Stainless steel interior bottom for greater durability, construction and appearance
- Holds 33° F to 41° F
- 2.5" thick foamed-in-place high density polyurethane insulation
- Self-contained side-mounted refrigeration with high humidity coated fin coil evaporator. Breathes from the front, back, and side
- Stainless steel lids and reinforced countertop
- Adjustable bullet feet for extra height requirements (if necessary)
- Laminated matte black exterior for extra durability against the elements
- Lid (door) locks standard
- Includes 3 vinyl coated wire bin dividers, adjustable in 2 inch increments
- Built-on removable bottle opener and cap catcher standard

OPTIONS

- Extra Bin Dividers Qty. _____
- Other Specify _____

MATERIALS

- INTERIOR: Stainless steel interior bottom for durability and appearance
Galvanized powder coated steel walls
- EXTERIOR: Stainless steel countertop and lids
Galvanized laminated matte black finish