



REACHING NEW HEIGHTS

1575 Zephyr Avenue
Hayward, CA 94544
Phone: (510) 477-3400
Fax: (510) 477-3412
www.ascendmfg.com
info@ascendmfg.com

© 2011 ASCEND is a registered trademark of Jimex Corporation

Date Modified 7/14/2011

ATM-20DT Freezer and Refrigerator

20 cu. ft.

PROJECT _____

QTY. ____ ITEM NO. _____

Standard Features

- 2 Year Parts & Labor Warranty
- 5 Year Compressor Warranty
- Fully Recessed Door Handles
- Hot Gas Anti-Sweat Door Heaters
- Sliding Shelf System
- Evaporative Hot Gas Condensate Pan
- Exterior LED Digital Temperature Control
- Automatic Defrost with Variable Temperature Controls on Freezer side
- Reinforced Door Hinges
- Environmentally Friendly CFC-free R-134A & R-404A Refrigerant
- Self-Contained Top Mounted Compressor
- 2.5" Inch Thick Foamed-In-Place Polyurethane Insulation
- 4 Adjustable Vinyl-Coated Wire Shelves
- Automatic Interior Lights in Freezer and Refrigerator Sections
- Fully Covered Interior Corners
- 5" Inch Casters Included
- Snap-in Magnetic Door Gaskets
- Standard Door Lock
- Automatic Door Closure with 90° Hold Open Feature
- Holds 33° F to 41° F as a refrigerator and holds -10° F to 10° F as freezer
- Assembled in the USA

Materials

- INTERIOR: Powder coated walls
- EXTERIOR: Stainless steel front powder coated exterior walls



ASCEND Energy Star Certified refrigerators save \$500 to \$650 in energy costs per lifetime



NSF/ANSI Standard 7

C US

GENERAL INFORMATION

Dimensions (inches): 29.1" (W) x 31.8" (D) x 76.2" (H)

Doors: 2 half doors

Unit Weight (lbs): 320

No. of Shelves: 4

Ship Weight (lbs): 350

Cubic Ft.: 10, 10

Shelf Size (inches): 20.75" x 25.25"

Cord Length (inches): 82

TECHNICAL DATA

Refrigerant: R-134A, R-404

Horsepower: 1/5, 1/4

Start Amps: 14.5

Volts: 115

Run Amps: 10.7

No. of Compressors: 2

ATM-20DT Freezer and Refrigerator

20 cu. ft.



- Energy Star Certified for Long Term Savings
- 2 Year Parts & Labor Warranty
- 5 Year Compressor Warranty
- Assembled in the USA



REACHING NEW HEIGHTS

1575 Zephyr Avenue
 Hayward, CA 94544
 Phone: (510) 477-3400
 Fax: (510) 477-3412
 www.ascendmfg.com
 info@ascendmfg.com

© 2011 ASCEND is a registered trademark of Jimex Corporation

DIMENSIONAL INFORMATION

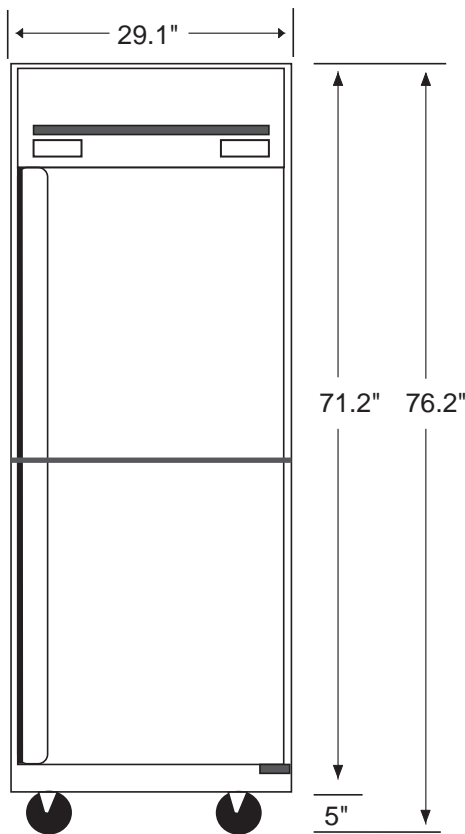
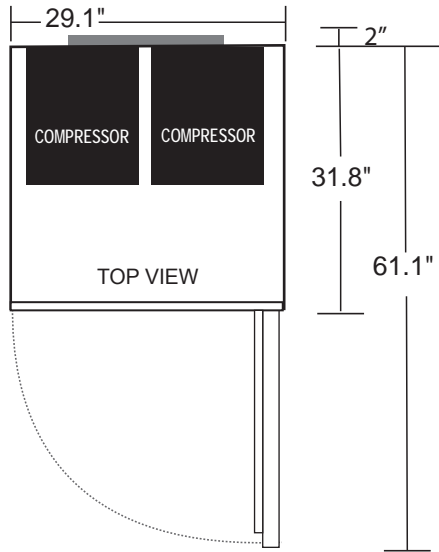

FRONT VIEW

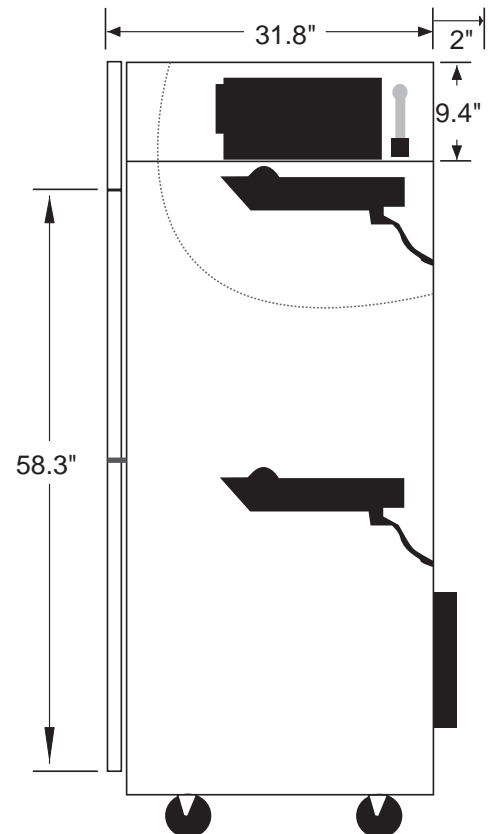

SIDE VIEW

ELECTRICAL PLUG



NEMA 5-15P plug
 5-15R receptacle
 required

AVAILABLE FACTORY OPTIONS

- ATM-20DT-LH: Left hinge option available
- ATM-20DT-FB: Freezer bottom configuration
- ATM-20DT-1G: 1 glass door option on refrigerator section available